

CENTRO™ 6459-2

DRAWER FOR LIFT DESK 6451-2/6452-2

INSTRUCTION MANUAL

LET'S GET STARTED.

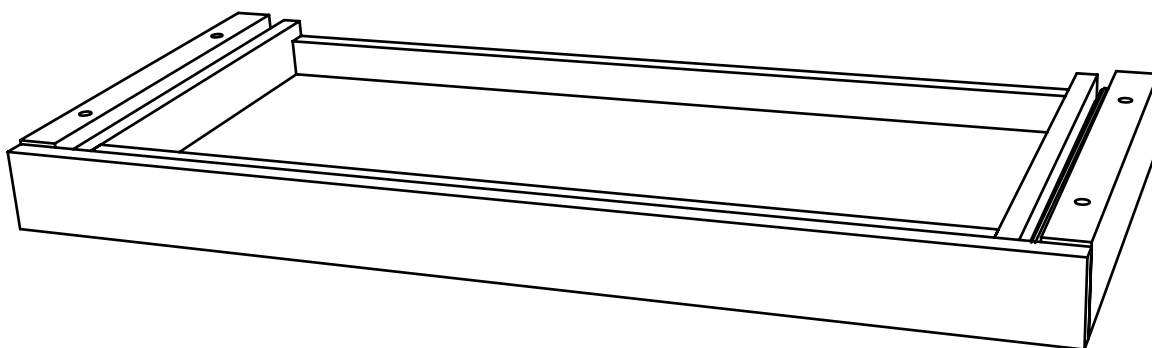

DESIGN MATTHEW WEATHERLY

BDi

BDIUSA.COM

Congratulations on the purchase of your Centro Drawer 6459-2 from BDI. Your desk has been designed to provide a lifetime of enjoyment. This manual will provide you with assembly instructions and other helpful information that will ensure that you get the most out of your desk. Please save it for future reference.

Your Centro Office furniture is designed for indoor use on level floors. It has been engineered for easy assembly. Please follow these directions carefully to prevent any damage.

Should you need further assistance, contact BDI at customerservice@bdiusa.com.

ENJOY!



HARDWARE AND COMPONENTS

Unpack and identify the parts listed below. The assembly workspace should be a non-marring surface such as carpet. For missing hardware pieces, please contact BDI Customer Service at customerservice@bdiusa.com.

Do not use power tools for assembly of this product.

For all other concerns, please contact your BDI retailer.

	
PART #	T1
DESCRIPTION	4mm Hex Wrench
QUANTITY	1

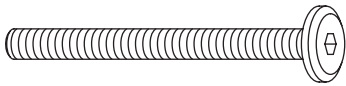
	
PART #	H10
DESCRIPTION	M6 x 60mm Screw
QUANTITY	4

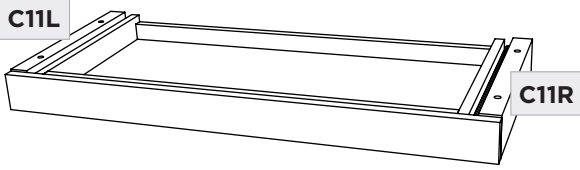
	
PART #	A2 with C11L / C11R Mounting Block
DESCRIPTION	Drawer
QUANTITY	1

	
PART #	C12
DESCRIPTION	Drawer Liner
QUANTITY	1

Attach the **(A2) Drawer Body** by inserting **4 (H10) Screws** through the holes on **(C11L)** and **(C11R) Mounting Blocks** and thread them into the 4 inserts on the bottom of your **Centro Desk 6451-2/6452-2** using the **(T1) Hex Wrench**.

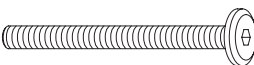
	PART/DESCRIPTION	QTY
	T1-HEX WRENCH	1
	H10-SCREW	4

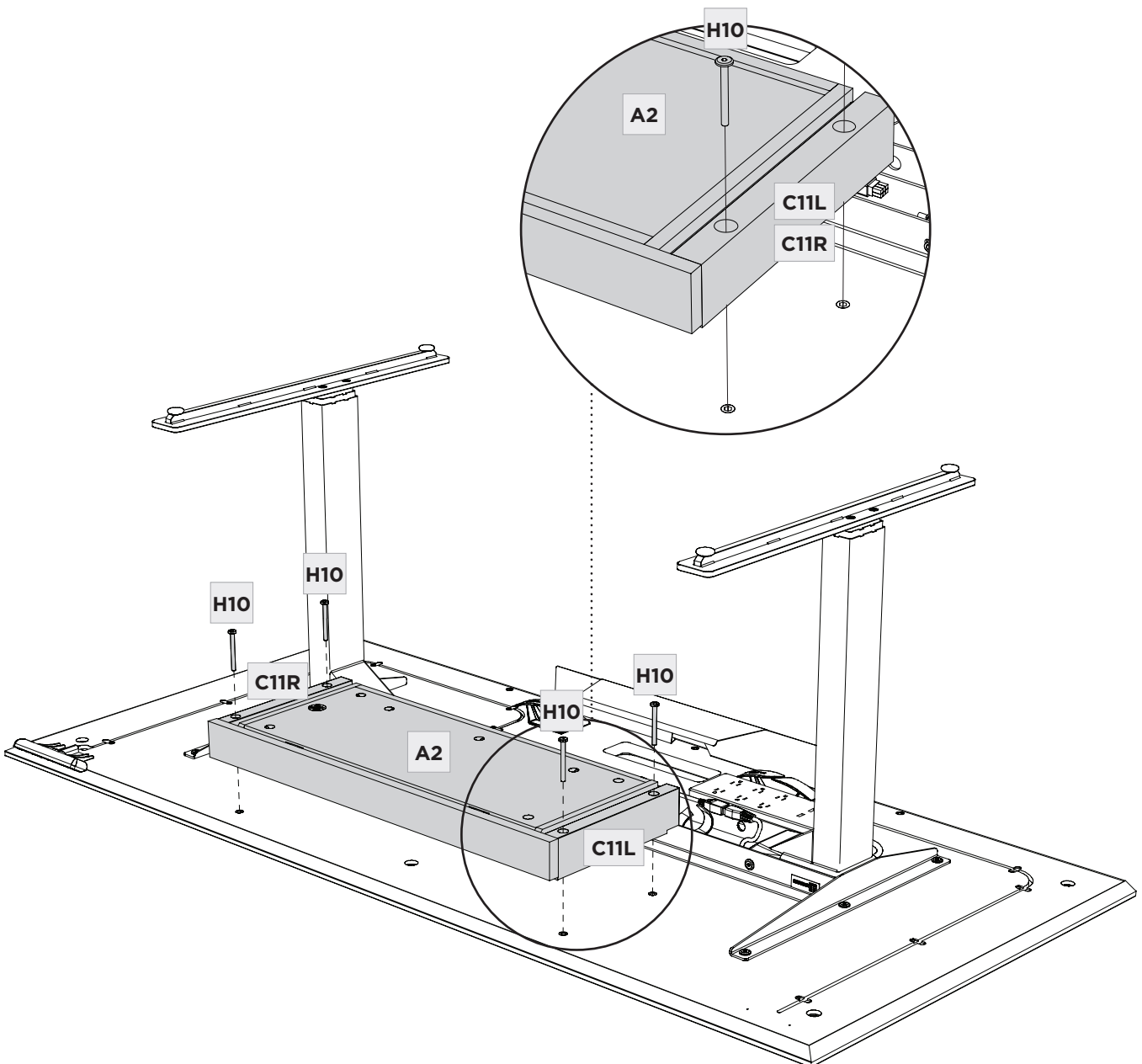

STEP 1. ATTACH DRAWER—OPTION 2

2 PERSON TASK



ASSEMBLY

IF YOUR DESK IS ALREADY FULLY ASSEMBLED

If your desk is already upright, install the drawer as follows. **This requires 2 people.** One person holds the **(A2) Drawer** under the desk. The other person inserts **(H10) Screws** into the holes in the side **(C11L)** and **(C11R) Mounting Blocks** using the **(T1) Hex Wrench** and threads them into the inserts under the desk. Start all 4 screws before fully tightening.

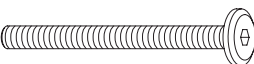
	PART/DESCRIPTION	QTY
	T1-HEX WRENCH	1
	H10-SCREW	4

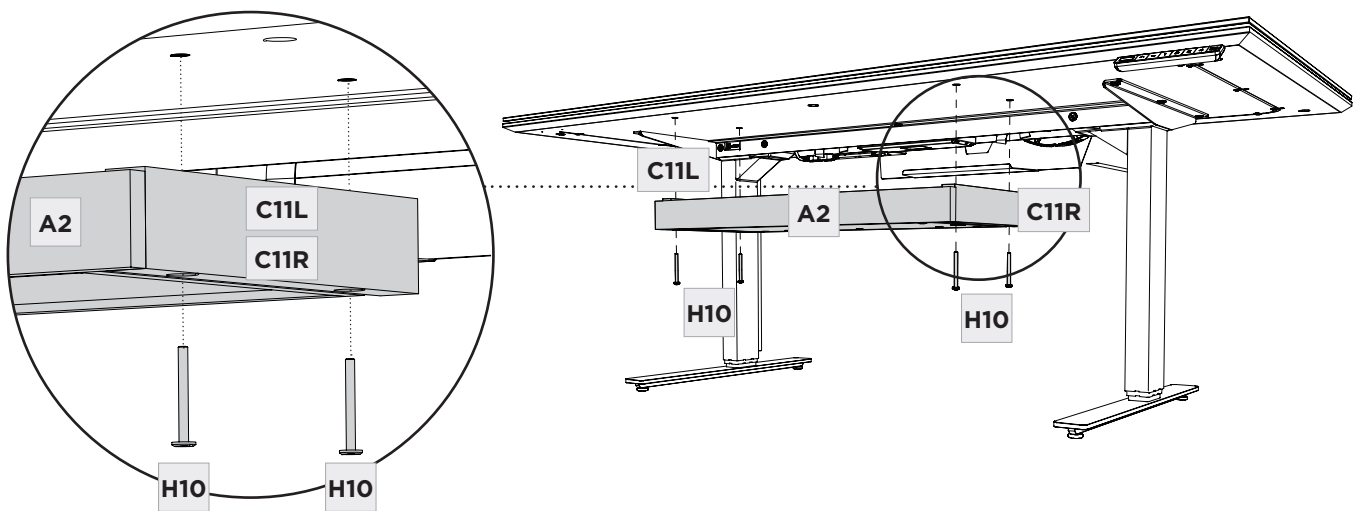

STEP 2. INSTALL DRAWER LINER

ASSEMBLY

Install the **(C12) Drawer Liner** into the **(A2) Drawer** as shown.

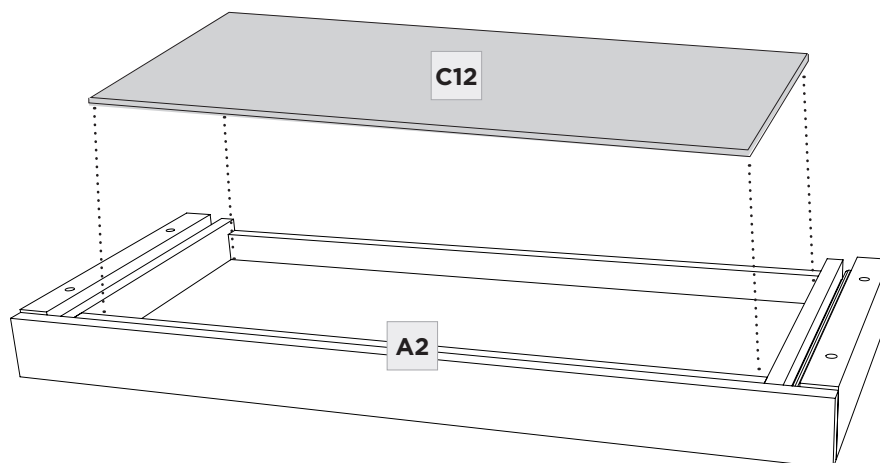

CARE & MAINTENANCE

GLASS

Glass surface is maintained using household glass cleaner and a paper towel or cloth.

SATIN-ETCHED GLASS

This uniquely smooth-to-the-touch glass surface can be regularly maintained using household glass cleaner and a paper towel or cloth. Minor scratches or scuffs not eliminated using paper towel or cloth can usually be removed by using a 'Magic Eraser'. Magic Eraser is a melamine foam product available at any grocery store or home improvement center. Dampen the entire glass surface as well as the Magic Eraser, then rub the entire glass surface in broad, even strokes using moderate pressure. Clean and dry the surface with a paper towel. Check for results and repeat as necessary.

Any scratches or scuffing not eliminated by one of the above methods can often be addressed by 'refreshing' the glass. This is a process that should not be required more than once per 6-12 months. See this brief video for the simple method: www.bdiusa.com/glass

WOOD

Wood surfaces should be cleaned with a slightly damp (not saturated) cloth or paper towel. Do not use glass cleaner on wood. If moisture remains, dry the surface with another cloth. If needed, a gentle non-abrasive cleanser may be used, but be sure to wipe away all cleaner residue and dry the surface with a cloth.

BDI's wood finishes feature natural hardwood solids and veneers. Wood is a product of nature and—unlike man-made materials that can be manufactured to strict and consistent specifications—has natural imperfections that are part of its appeal and character. Every piece of wood differs from every other, even when coming from the very same tree. As such, variation in grain, texture and tone should be expected from one panel or piece of furniture to the next.

While BDI's stained wood finishes are stable in tone & appearance, all finishes are subject to some degree of discoloration with prolonged exposure to direct sunlight. Please take care to avoid positioning your BDI cabinet in any area with extensive direct sunlight. To learn more about the features of natural wood, visit www.bdiusa.com/wood

METAL & PAINTED SURFACES

Surfaces should be cleaned with a slightly damp (not saturated) cloth or paper towel. If moisture remains, dry the surface with another cloth. If needed, a gentle non-abrasive cleanser may be used, but be sure to wipe away all cleaner residue and dry the surface with a cloth.

WARRANTY

BDI warrants to the original purchaser that for the below stated warranty term, BDI will repair or replace any product, part, or component covered by this warranty which fails under normal use as a result of a defect in material or workmanship. BDI will repair or replace the aforementioned product, part or component with a comparable product, part or component. The decision to repair or replace will be at BDI's sole discretion.

BDI Home Theater Furniture, Office Furniture, Modular Systems, Tables and other furniture pieces are warranted for three (3) years from the date of purchase as shown on your sales receipt. The warranty period starts from the date of purchase. This warranty extends only to the original purchasers who acquire new product from BDI Authorized Resellers. Any product, part, or component must have been assembled, installed, used, and maintained according to BDI's published instructions in order to be eligible for warranty coverage. Any modification to the original product voids the warranty.

To view BDI's complete warranty information, visit www.bdiusa.com/warranty

PRODUCT REGISTRATION

Registering your new BDI product allows us to send you important product updates, service information and helpful hints related to your BDI products. Register today, and you will be entered to win free a BINK table from BDI: www.bdiusa.com/register



WARNING

SERIOUS OR FATAL CRUSHING INJURIES CAN OCCUR FROM FURNITURE TIP-OVER. TO HELP PREVENT TIP-OVER:

- Install tip-over restraint.
- Place heaviest items in lower compartments.
- Never allow children to climb or hang on drawers, doors or shelves.
- Never open more than one drawer at a time.

USE OF TIP-OVER RESTRAINT MAY REDUCE—BUT NOT ELIMINATE—THE RISK OF TIP-OVER.



BDIUSA.COM

These distinctive product configurations are protected by US and international patents, trade dress, and/or copyright laws. Centro & BDI are trademarks of Becker Designed, Inc. All rights reserved. ©2020, BDI | V.05.28.2020

Made in Vietnam.

LEFT TEMPLATE

DRAWER 6159/6459-2

Place Against Inside of Edge of Frame Bracket

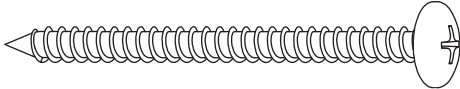

PART #	H11
DESCRIPTION	#8 x 2.5 in Wood Screw
QUANTITY	4

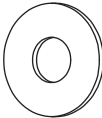

PART #	H12
DESCRIPTION	Washer
QUANTITY	4

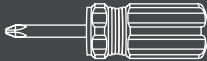

TOOL REQUIRED (NOT INCLUDED)	
Phillips Screwdriver	

Outside Edge of Drawer Block

Align Front Edge of Drawer Block with Arrow



Align with Border Between Black Panel and Solid Wood Edge

RIGHT TEMPLATE

DRAWER 6159/6459-2



The 6159 and 6459-2 Drawer Box may be installed on a Sequel 20 6151/6152 or Centro 6451-2/6452-2 Lift Desk using the provided 6159/6459-2 instruction booklet and machine screws.

If you are installing the 6159 or 6459-2 Drawer Box on a Sequel 6051/6052 or Centro 6451/6452 Lift Desk please follow these instructions:

1. Put the desk in its lowest position and, with the help of another person, safely place the desk in an upside down position. Place on a soft, non marring surface such as carpet with the front edge facing you.
2. Line up the outside edge of the template against the inside edge of the black frame bracket.
3. Line up the front edge of the template along the border between the black panel and the solid wood edge at the front of the desk.
4. Repeat for the other side of the template.
5. Place drawer between the templates such that the front of the **(C11L)** and **(C11R) Mounting Blocks** line up with the arrows printed on the templates.
6. Using a #2 Phillips head screwdriver, or a power drill with a #2 Phillips bit installed, carefully attach the **(A2) Drawer Body** to the desk by inserting the provided **(H11) Wood Screws** and **(H12) Washers** through the holes on the **(C11L)** and **(C11R) Mounting Blocks**. If using a power drill with a clutch setting, it is recommended to set the clutch to no more than 9 lbs.
7. You may now return your desk to its upright position.

Outside Edge of Drawer Block

Place Against Inside of Edge of Frame Bracket

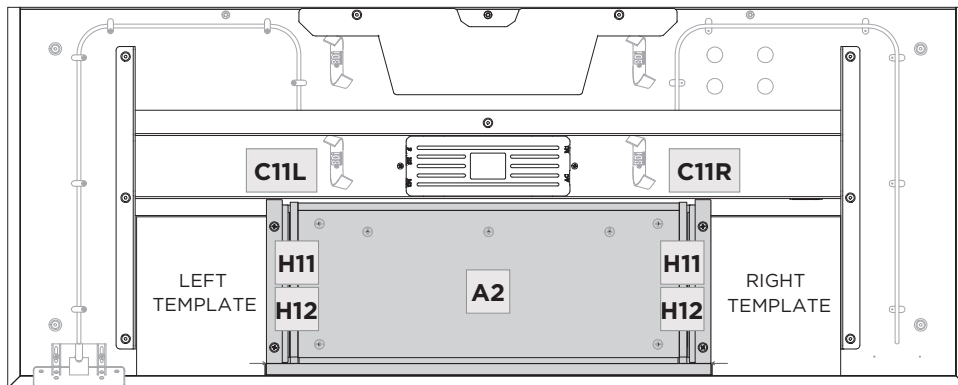

Align Front Edge of Drawer Block with Arrow

Align with Border Between Black Panel and Solid Wood Edge